



## Disc Sanders INSTRUCTIONS MANUAL – 2 in (50 mm) 20,000 RPM .33 HP, 2 in (50 mm) 20,000 RPM .5 HP, 3 in (76 mm) 15,000 RPM 1 HP

### Important Safety Information

Please read, understand and follow all safety information contained in these instructions prior to the use of this tool.  
Retain these instructions for future reference.

### Intended Use

This pneumatic tool is designed to be used with the sander adaptor, disc pad, and appropriate abrasive for sanding metals, wood, stone, plastics and other materials. Additionally, when used with the collet chuck it may also function as a Die Grinder. It should only be used for such sanding and die grinding applications and within its marked capacity and ratings. Only accessories specifically recommended by 3M should be used with this tool. Use in any other manner or with other accessories could lead to unsafe operating conditions.

Do not operate tool in water or in an excessively wet application.

Do not use back up pads that have a Max RPM less than the tool Max RPM rating.

### Explanation of Signal Word Consequences

	<b>WARNING:</b> Indicates a potentially hazardous situation which, if not avoided, may result in death or serious injury and/or property damage.
	<b>CAUTION:</b> Indicates a potentially hazardous situation which, if not avoided, may result in minor or moderate injury and/or property damage.

Read the Material Safety Data Sheets (MSDS) before using any materials.

Contact the suppliers of the workpiece materials and abrasive materials for copies of the MSDS if one is not readily available.

**WARNING**

Exposure to **DUST** generated from workpiece and/or abrasive materials can result in lung damage and/or other physical injury.

Use dust capture or local exhaust as stated in the MSDS. Wear government-approved respiratory protection and eye and skin protection.

Failure to follow this warning can result in serious lung damage and/or physical injury.



### WARNING

#### To reduce the risks associated with impact from abrasive product, disc pad, or tool breakup, sharp edges, hazardous pressure, rupture, vibration and noise:

- Read, understand and follow the safety information contained in these instructions prior to the use of this tool. Retain these instructions for future reference.
- Only personnel who are properly trained should be allowed to service this tool.
- Practice safety requirements. Work alert, have proper attire, and do not operate tools under the influence of alcohol or drugs.
- Operators and other personnel must always wear protection for eyes, ears, and respiratory protection when in the work area or while operating this product. Follow your employer's safety policy for PPE's and/or ANSI Z87.1 or local/national standards for eyewear and other personal protective equipment requirements.
- Wear protective apparel, taking into consideration the type of work being done.
- Never exceed marked maximum input pressure (90psi / .62Mpa / 6.2Bars).
- Proper eye protection must be worn at all times.
- Tool shall not be operated in the presence of bystanders.
- If you notice any abnormal noise or vibration when operating the product, immediately discontinue its use and inspect for worn or damaged components (mounting hardware, abrasive product, etc). Correct or replace the suspect component. If abnormal noise or vibration still exists, return the tool to 3M for repair or replacement. Refer to warranty instructions.
- Never operate this tool without all safety features in place and in proper working order.
- Do not remove or disable safety feature of on-off control device.
- Make sure the tool is disconnected from its air source before servicing, inspecting, maintaining, cleaning, and before changing abrasive product.
- Only use abrasive disc pads and other accessories supplied by 3M.
- Prior to use, inspect abrasive product, disc pad, and other accessories for possible damage. If damaged, replace with new abrasive product and accessories available from 3M.

## WARNING

- Never over-ride the safety start-stop control such that it is in the on position.
- Use only with mounting hardware recommended by 3M; check with 3M for mounting hardware requirements.
- Always ensure that shaft diameters match internal diameters of the collet inserts.
- Maximum operating speed of abrasive products or accessories must be reduced whenever the exposed length of shaft (overhang) is longer than corresponding 3M approved products.
- Always ensure that a minimum of 10mm shaft gripping length is observed.
- Never install and use router bits or cutting-off wheels in a die grinder tool (which is unguarded).
- Use only with abrasive products not requiring guards according to local, state and federal regulations.

### **To reduce the risks associated with vibration:**

- If any physical hand/wrist discomfort is experienced, work should be stopped promptly to seek medical attention. Hand, wrist and arm injury may result from repetitive work, motion and overexposure to vibration.

### **To reduce the risks associated with loud noise:**

- Always wear protection for eyes, ears, and respiratory protection while operating this product. Follow your employer's safety policy for PPE's and/or ANSI Z87.1 or local/national standards for eyewear and other personal protective equipment requirements.

### **To reduce the risks associated with fire or explosion:**

- Do not operate the tool in explosive atmospheres, such as in the presence of flammable liquids, gases, or dust. The abrasives are able to create sparks when working material, resulting in the ignition of the flammable dust or fumes.

### **To reduce the risks associated with hazardous dust ingestion or eye/skin exposure:**

- Use appropriate respiratory and skin protection, or local exhaust as stated in the MSDS of the material being worked on.

### **To reduce the risks associated with hazardous voltage:**

- Do not allow this tool to come into contact with electrical power sources as the tool is not insulated against electrical shock.

## CAUTION!

### **To reduce the risks associated with skin abrasion, burns, cuts, or entrapment:**

- Keep hands, hair, and clothing away from the rotating part of the tool.
- Wear suitable protective gloves while operating tool.
- Do not touch the rotating parts during operation for any reason.
- Do not force tool or use excessive force when using tool.

### **To reduce the risks associated with whipping:**

- Ensure supply hose is oil resistant and is properly rated for required working pressure.
- Do not use tools with loose or damaged air hoses or fittings.

### **To reduce the risks associated with fly off of abrasive product parts:**

- Use care in attaching abrasive product, disc pad, and mounting hardware; following the instructions to ensure that they are securely attached to the tool before use.

### **To reduce the risks associated with hazardous pressure-rupture:**

- Be aware that incorrectly installed hoses and fittings might unexpectedly come loose at any time and create a whipping/impact hazard.

**PARTS LIST FOR PT# 20230 & 25123, 20000 RPM, 2", .33 HP DISC SANDER**

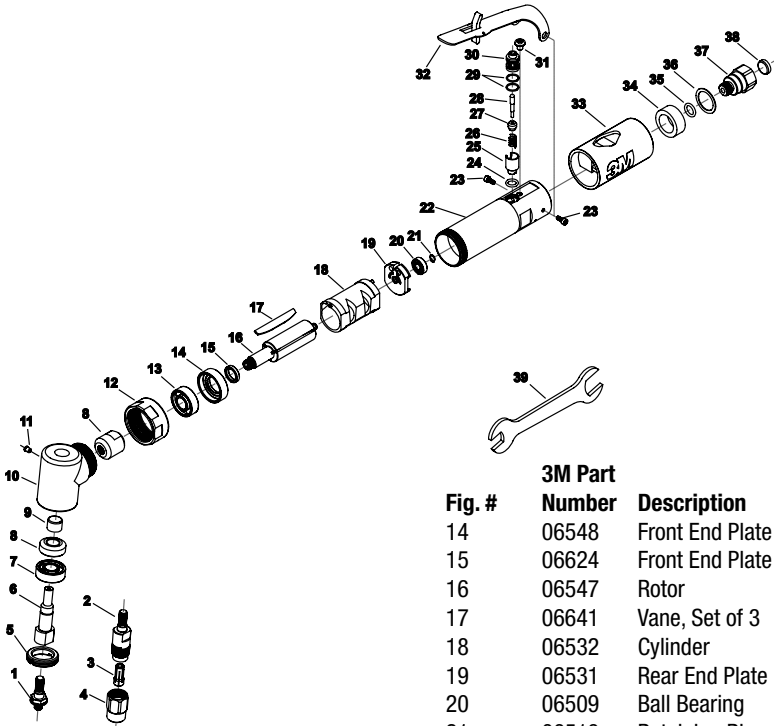

Fig. #	3M Part Number	Description
1	06582	Sander Adapter
2	06583	Collet Body
3	06528	Collet (1/4")
3	06529	Collet (1/8")
3	06530	Collet (3/16")
3	06540	Collet (3 mm)
3	06541	Collet (6 mm)
4	06516	Collet Nut
5	06633	Lock Nut
6	06581	Output Shaft
7	06611	Ball Bearing
8	06645	Bevel Gear Set
9	06505	Needle Bearing
10	06551	Angle Head Assembly (Includes Figures 9 & 11)
11	06523	Grease Fitting
12	06549	Clamp Nut
13	06510	Ball Bearing 3/8" x 7/8" x 9/32"

Fig. #	3M Part Number	Description
14	06548	Front End Plate
15	06624	Front End Plate Spacer
16	06547	Rotor
17	06641	Vane, Set of 3
18	06532	Cylinder
19	06531	Rear End Plate
20	06509	Ball Bearing
21	06519	Retaining Ring
22	06533	Housing Assembly (Includes Figures 23-32)
23	06500	Socket Head Cap Screw, 4-40 (2)
24	06512	O-Ring
25	06536	Speed Control Valve
26	06517	Spring
27	06514	Rubber Valve
28	06537	Valve Plunger
29	06515	O-Ring (2)
30	06535	Valve Body
31	06502	Screw 8-32 x 3/16" Pan Phil Mac
32	06538	Safety Lever Assembly
33	06606	Grip
34	06539	Silencer Pad
35	06513	O-Ring
36	06525	Washer
37	06534	Inlet Adapter
38	06623	Screen
39	06586	7/16" x 11/16" Wrench (2)

**PARTS LIST FOR PT# 20231 & 25124, 20000 RPM, 2", .5 HP DISC SANDER**

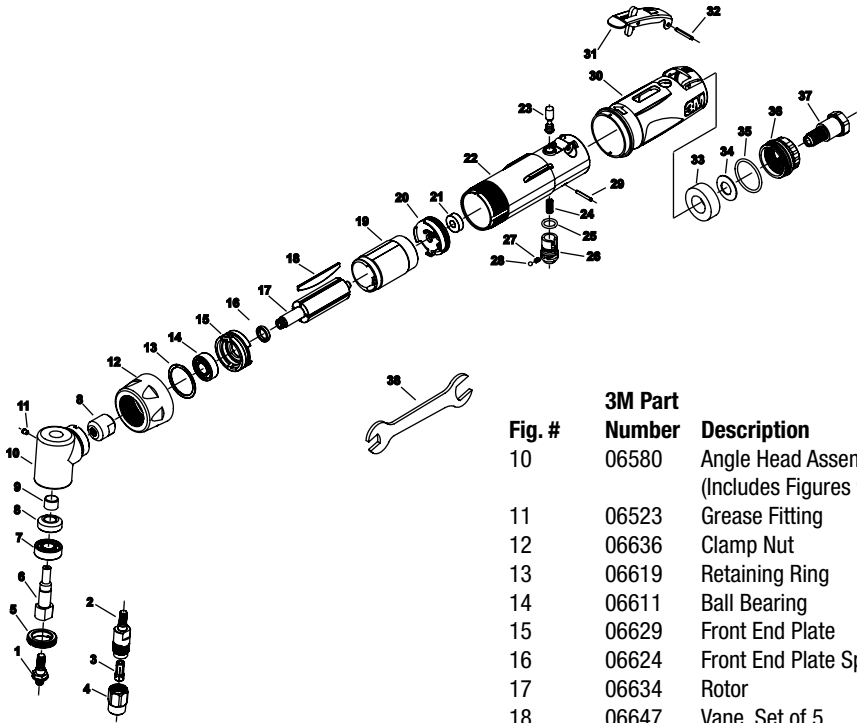

Fig. #	3M Part Number	Description
1	06582	Sander Adapter
2	06583	Collet Body
3	06528	Collet (1/4")
3	06529	Collet (1/8")
3	06530	Collet (3/16")
3	06540	Collet (3 mm)
3	06541	Collet (6 mm)
4	06516	Collet Nut
5	06633	Lock Nut
6	06581	Output Shaft
7	06611	Ball Bearing
8	06645	Bevel Gear Set
9	06505	Needle Bearing

Fig. #	3M Part Number	Description
10	06580	Angle Head Assembly (Includes Figures 9 & 11)
11	06523	Grease Fitting
12	06636	Clamp Nut
13	06619	Retaining Ring
14	06611	Ball Bearing
15	06629	Front End Plate
16	06624	Front End Plate Spacer
17	06634	Rotor
18	06647	Vane, Set of 5
19	06631	Cylinder Liner
20	06630	Rear End Plate
21	06612	Ball Bearing
22	06625	Housing
23	06626	Trigger Valve Stem
24	06614	Compression Spring
25	06620	O-Ring
26	06627	Air Regulator
27	06613	Compression Spring
28	06622	Steel Ball
29	06616	Pin
30	06599	Housing Cover, .5 HP
31	06635	Paddle Assembly
32	06617	Roll Pin
33	06632	Muffler Material
34	06615	Disc Spring
35	06621	O-Ring
36	06628	Exhaust Deflector
37	06618	Inlet Bushing
38	06586	7/16" x 11/16" Wrench (2)

**PARTS LIST FOR PT# 20232 & 25125, 15000 RPM, 3", 1 HP DISC SANDER**

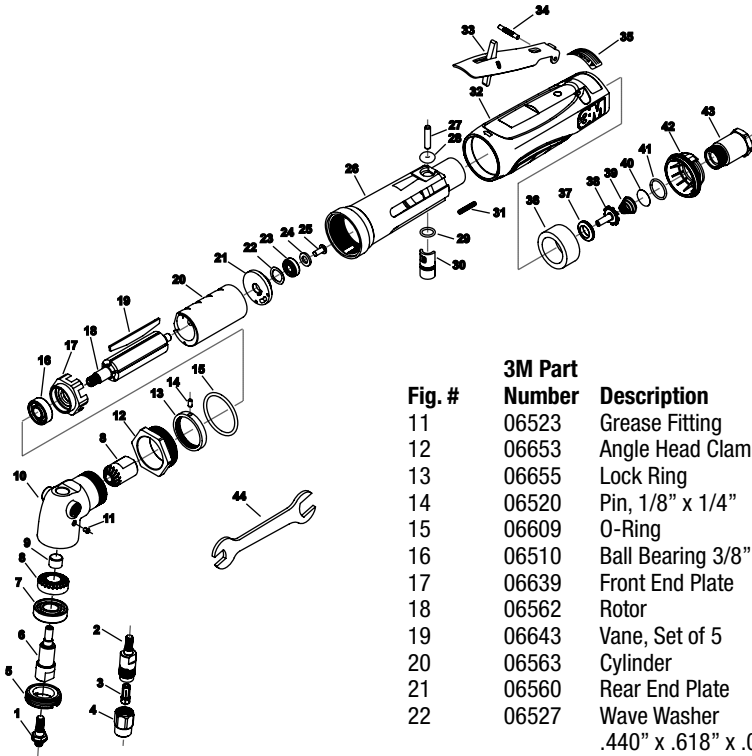

Fig. #	3M Part Number	Description
1	06582	Sander Adapter
2	06583	Collet Body
3	06528	Collet (1/4")
3	06529	Collet (1/8")
3	06530	Collet (3/16")
3	06540	Collet (3 mm)
3	06541	Collet (6 mm)
4	06516	Collet Nut
5	06578	Bearing Retainer
6	06591	Output Shaft
7	06507	Ball Bearing
8	06646	Spiral Bevel Gear Set
9	06505	Needle Bearing
10	06637	Angle Head Assembly (Includes Figures 9 & 11)

Fig. #	3M Part Number	Description
11	06523	Grease Fitting
12	06653	Angle Head Clamp Nut
13	06655	Lock Ring
14	06520	Pin, 1/8" x 1/4"
15	06609	O-Ring
16	06510	Ball Bearing 3/8" x 7/8" x 9/32"
17	06639	Front End Plate
18	06562	Rotor
19	06643	Vane, Set of 5
20	06563	Cylinder
21	06560	Rear End Plate
22	06527	Wave Washer .440" x .618" x .008"
23	06508	Ball Bearing
24	06567	Washer .251" x .468" x .063"
25	06568	Screw #8-32 x 3/8" But Hd Cap
26	06638	Housing
27	06558	Torr Pin, 3/16" x 7/8"
28	06543	O-Ring
29	06511	O-Ring
30	06556	Regulator
31	06501	Screw, 6-32 x 3/4" Set Soc Hex
32	06598	Housing Cover
33	06642	Lever
34	06559	Groove Pin, 1/8" x 7/8" Type E
35	06566	Warning Label
36	06557	Muffler
37	06552	Throttle Valve Seat
38	06553	Throttle Valve
39	06554	Taper Spring
40	06555	Screen
41	06608	O-Ring, 1/16" x 5/8" x 3/4"
42	06604	Rotatable Exhaust Deflector
43	06605	Inlet Bushing
44	06586	7/16" x 11/16" Wrench (2)

## Product Configuration/Specifications:

Model Number	Collet	Pad Type	Pad Part	Speed RPM	Power (hp)	Product Net Wt.kg. (lb.)	Height mm (in.)	*Noise Level dBA Pressure (Power)	** Vibration Level m/s <sup>2</sup> (ft/s <sup>2</sup> )	** Uncertainty K m/s <sup>2</sup>	** Vibration Level Configured as Grinder m/s <sup>2</sup> (ft/s <sup>2</sup> )	** Uncertainty K Configured as Grinder m/s <sup>2</sup>
20230	1/4"	2" Roloc	88746	20,000	0.33	0.49 (1.08)	63.5 (2.5)	82.4 (94)	3.25 (10.7)	1.625	7.57 (24.9)	3.028
25123	6 mm	Hard				0.49 (1.08)	63.5 (2.5)	82.4 (94)	3.25 (10.7)		1.625	
20231	1/4"	2" Roloc	88746	20,000	0.5	0.58 (1.28)	69.9 (2.75)	89.3 (100.9)	6.56 (21.6)	2.624	7.41 (24.4)	2.964
25124	6 mm	Hard				0.58 (1.28)	69.9 (2.75)	89.3 (100.9)	6.56 (21.6)		2.624	
20232	1/4"	3" Roloc	45091	15,000	1	0.89 (1.97)	82.6 (3.25)	84.5 (95.1)	5.98 (19.7)	2.392	4.87 (16.0)	1.948
25125	6 mm	Hard				0.89 (1.97)	82.6 (3.25)	84.5 (95.1)	5.98 (19.7)		2.392	

\* Declared noise levels; measurements carried out in accordance with standard EN ISO 15744:2002.

\*\* Declared vibration levels in accordance with EN12096; measurements carried out in accordance with standard EN ISO 8662-8:1997 for disc sander application and EN ISO 8662-13:1997 for die grinder application. The noise and vibration values stated in the table are from laboratory testing in conformity with stated codes and standards and are not sufficient risk evaluation. Values measured in a particular work place may be higher than the declared values. The actual exposure values and amount of risk or harm experienced to an individual is unique to each situation and depends upon the surrounding environment, the way in which the individual works, the particular material being worked, work station design, as well as upon the exposure time and the physical condition of the user. 3M cannot be held responsible for the consequences of using declared values instead of actual exposure values for any individual risk assessment.

## Operating / Maintenance Instructions

### PRIOR TO THE OPERATION

The tool is intended to be operated as a hand held tool. It is always recommended that while using the tool, operators stand on a solid floor, in a secure position with a firm grip and footing. Be aware that the sander can develop a torque reaction. See the section "SAFETY PRECAUTIONS".

Ensure that all abrasive articles are mounted concentrically on the supporting disc pad.

Use a clean lubricated air supply that will give a measured air pressure at the tool of 6.2 bar (90 psig) when the tool is running with the lever fully depressed. It is recommended to use an approved 10 mm (3/8 in) x 8 m (25 ft) maximum length airline. Connect the tool to the air supply as shown in Figure 1. Do not connect the tool to the airline system without an easily accessible air shut off valve. It is strongly recommended that an air filter, regulator and lubricator (FRL) be used as shown in Figure 1 as this will supply clean, lubricated air at the correct pressure to the tool. In any case appropriate air pressure regulators shall be used at all times while operating this tool where the supply pressure exceeds the marked maximum of the tool. Details of such equipment can be obtained for your tool distributor. If such equipment is not used, the tool should be manually lubricated. To manually lubricate the tool, disconnect the airline and put 2 to 3 drops of suitable pneumatic motor lubricating oil such as 3M™ Air Tool Lubricant PN 20451, Fuji Kosan FK-20 or Mobil ALMO 525 into the hose end (inlet) of the tool. Reconnect tool to the air supply and run tool slowly for a few seconds to allow air to circulate the oil. If the tool is used frequently, lubricate it on a daily basis or lubricate it if the tool starts to slow or lose power. It is recommended that the air pressure at the tool be 6.2 bar (90 psig) while the tool is running so the maximum RPM is not exceeded. The tool can be run at lower pressures but should never be run higher than 6.2 bar (90 psig). If run at lower pressure the performance of the tool is reduced.

Recommended Airline Size - Minimum		Recommended Maximum Hose Length		Air Pressure		
10 mm	3/8 in	8 meters	25 feet	Maximum Working Pressure	6.2 bar	90 psig
				Recommended Minimum	NA	NA

Lubricate the angle head every 6-8 working hours with premium grease with the following properties:

- High and low temperature performance
- Shear stable
- Anti-wear protection
- Low viscosity base fluid for high speed application
- Very low coefficient of friction

Fuchs Renolit AX S2 or equal is recommended. Grease gun and grease available from your grease supplier.

## Safety Precautions

1. Read all instructions before using this tool. All operators must be fully trained in its use and aware of these safety rules.
2. The tool RPM should be checked on a regular basis (at shift change).
3. Make sure the tool is disconnected from the air supply. Attach the 3M™ Roloc™ Disc Pad to the sander adaptor using the wrenches supplied with the tool. Select a suitable abrasive and secure it to the back up pad.
4. Always wear required safety equipment when using this tool.
5. When sanding always start the tool just prior to contacting the work piece. Stop air flow to the tool as it is removed from the work piece.
6. Always remove the air supply to the sander before fitting, adjusting or removing the abrasive or disc pad.
7. Always adopt a firm footing and grip and be aware of torque reaction developed by the sander.
8. Use only 3M approved spare parts.
9. Always ensure the material being worked is firmly fixed to avoid movement.
10. Check hose and fittings regularly for wear. Do not carry the tool by its hose; always be careful to prevent the tool from being started when carrying the tool with the air supply connected.
11. If tool is serviced or rebuilt check to ensure that the maximum tool RPM is not exceeded and that there is no excessive tool vibration.
12. Dust can be highly combustible.
13. Do not exceed maximum recommended air pressure. Use safety equipment as recommended.
14. Prior to installing any sanding or polishing accessory, always check that it's marked maximum operating speed is equal or higher than the rated speed of this tool.
15. The tool is not electrically insulated. Do not use where there is a possibility of contact with live electricity, gas pipes, and/or water pipes.
16. This tool is not protected against hazards inherent in grinding and cutting operations, which require a guard, and no such grinding and cutting products should ever be attached.
17. Take care to avoid entanglement with the moving parts of the tool with clothing, ties, hair, cleaning rags or loose hanging objects. If entangled, stop air supply immediately to avoid contact with moving tool parts.
18. Keep hands clear of the spinning pad during use.
19. If the tool appears to malfunction, remove from use immediately and arrange for service and repair.
20. Immediately release the start handle in the event of any disruption of pressure; do not attempt to re-start until the disruption has been corrected.
21. When tool is not in use, store in a clean dry environment free of debris.
22. Recycle or dispose of tool according to Local, State, and Federal regulations.

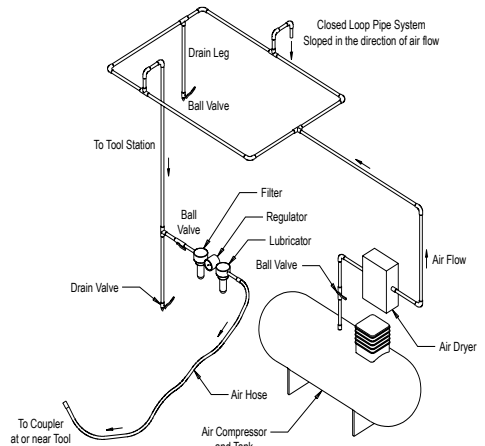

Figure 1

## 3M™ Roloc™ Disc Pads

3M™ Roloc™ Disc Pads are perfectly mated for use on the 3M Sander. Constructed from premium, industrial-quality materials and their durability and precise construction are the ideal complement to the performance of the 3M Sander. See Product Configuration/Specifications table for the correct replacement pad for a particular model.

See 3M ASD Accessory catalog 61-5002-8098-9 and Fantastic Finishes & More catalog 61-5002-8097-1 for additional Disc Pads and Accessories.

## Removing the sander adaptor and installing the collet chuck

1. Disconnect air line from tool.
2. Using the wrenches supplied with the tool, secure the output shaft with one of the wrenches. Loosen the sander adaptor with the other wrench. Remove the sander adaptor and store in a safe place for use at another time.
3. Thread the collet chuck supplied with the tool into the threaded hole vacated by the sander adaptor.
4. Tighten the base of the collet chuck with the two wrenches.
5. Loosen the collar of the chuck to allow the appropriate shank to be inserted (¼ in collet insert is used for ¼ in shanks, 6 mm collet insert is used for 6 mm shanks).
6. Insert shank completely into the collet and tighten with the two wrenches. An inadequately inserted shank could bend or break causing damage to the tool and work piece and possible injury to the operator or bystanders.

**Product Use:** All statements, technical information and recommendations contained in this document are based on tests or experience that 3M believes are reliable. However, many factors beyond 3M's control can affect the use and performance of a 3M product in a particular application, including the conditions under which the 3M product is used and the time and environmental conditions in which the product is expected to perform. Since these factors are uniquely within the user's knowledge and control, it is essential that the user evaluate the 3M product to determine whether it is fit for a particular purpose and suitable for the user's method of application.

**Warranty and Limited Remedy:** 3M warrants this tool against defects in workmanship and materials under normal operating conditions for one (1) year from the date of purchase. 3M MAKES NO OTHER WARRANTIES, EXPRESS OR IMPLIED, INCLUDING, BUT NOT LIMITED TO, ANY IMPLIED WARRANTY OF MERCHANTABILITY OR FITNESS FOR A PARTICULAR PURPOSE OR ANY IMPLIED WARRANTY ARISING OUT OF A COURSE OF DEALING, CUSTOM OR USAGE OF TRADE. User is responsible for determining whether the 3M tool is fit for a particular purpose and suitable for user's application. User must operate the tool in accordance

with all applicable operating instructions, safety precautions, and other procedures stated in the operating manual to be entitled to warranty coverage. 3M shall have no obligation to repair or replace any tool or part that fails due to normal wear, inadequate or improper maintenance, inadequate cleaning, non-lubrication, improper operating environment, improper utilities, operator error or misuse, alteration or modification, mishandling, lack of reasonable care, or due to any accidental cause. If a tool or any part thereof is defective within this warranty period, your exclusive remedy and 3M's sole obligation will be, at 3M's option, to repair or replace the tool or refund the purchase price.

**Limitation of Liability:** Except where prohibited by law, 3M and seller will not be liable for any loss or damage arising from the 3M product, whether direct, indirect, special, incidental or consequential, regardless of the legal theory asserted, including warranty, contract, negligence or strict liability.

**Submitting a Warranty Claim:** Contact your dealer when submitting a warranty claim in accordance with the restrictions listed above. Please note that all warranty claims are subject to manufacturer's approval. Be sure to keep your sales receipt in a safe place. This must be submitted when filing a warranty claim, within 1 year from the date of purchase.

**Product Repair after Warranty has Expired**  
3M does not offer repair service for product out of warranty.

<b>EC Declaration of Conformity</b>		<b>CE</b>
<b>Manufacturers Name:</b>	<b>3M</b> , Abrasives Systems Division	
<b>Manufacturers Address:</b>	3M Center, Building 223-6N-02 St Paul, MN USA 55144	
<b>Does hereby declare that the machinery described below complies with those applicable essential health and safety requirements of the Machinery Directive 98/37/EC; together with all amendments to date.</b>		
<b>Descriptions:</b>	3M™ Disc Sander, 2in.(51mm), 0.3 hp (224w), MOS 20,000 rpm, 7" Offset Head, 1/2" collet 3M™ Disc Sander, 2in.(51mm), 0.5 hp (273w), MOS 20,000 rpm, 7" Offset Head, 1/2" collet 3M™ Disc Sander, 3in.(76mm), 1 hp (746w), MOS 15,000 rpm, 7" Offset Head, 1/2" collet 3M™ Disc Sander, 2in.(51mm), 0.3 hp (224w), MOS 20,000 rpm, 7" Offset Head, 9mm collet 3M™ Disc Sander, 2in.(51mm), 0.5 hp (273w), MOS 20,000 rpm, 7" Offset Head, 9mm collet 3M™ Disc Sander, 3in.(76mm), 1 hp (746w), MOS 15,000 rpm, 7" Offset Head, 9mm collet	
<b>Model Numbers:</b>	20230, 20231, 20232, 25123, 25124, 25125	
<b>The following standards have either been referred to, or complied with, in full or in part as relevant:</b>		
EN ISO 12100-1:2003	Safety of machinery. Basic concepts, general principles for design – Basic terminology and Technical principles	
EN ISO 12100-2:2003	Safety of machinery. Basic concepts, general principles for design – Basic terminology and Technical principles	
EN 792-8:2001	Hand-held non-electric power tools – Safety Requirements – Part 8: Sanders and Polishers	
EN 792-9:2001	Hand-held non-electric power tools – Safety Requirements – Part 9: Die Grinders	
EN 983:1996	Safety of machinery. Safety requirements for fluid power systems and components - Pneumatics	
EN ISO 14121-1:2007	Safety of machinery. Risk assessment principles	
EN ISO 28662-1:1992	Hand-held portable power tools – Measurement of vibrations at the handle – Part 1: General	
EN ISO 8662-8:1997	Hand-held portable power tools – Measurement of vibrations at the handle – Part 8: Polishers and rotary, orbital and random orbital sanders	
EN ISO 8662-13:1997	Hand-held portable power tools – Measurement of vibrations at the handle – Part 13: Die Grinders	
EN ISO 15744:2002	Hand-held non-electric power tools. Noise measurement code. Engineering method (grade 2)	
<b>Full Name of responsible person.</b>		
Stefan A. Babirad	<b>Position:</b> Technical Director	
<b>Signature:</b> <i>Stefan A. Babirad</i>	<b>Date:</b> 6/26/2008	

**3M**  
Abrasive Systems Division  
3M Center, Building 223-6N-02  
St. Paul, MN 55144-1000  
www.3M.com/abrasives

© 3M 2008  
3M and Roloc are trademarks of 3M Company  
34-8701-2619-9

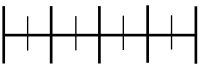

Contact: Michelle Dumas  
Creator: deZinnia  
Spec # 34-8701-2619-9  
Structure: SS-12395  
Ink: Black  
Date: 07/23/08

Scale:  1 Inch

**Version 1**